

**SESAME**

**“Light in uncertain times: SESAME,  
Science, and the Middle East”**

**Gihan Kamel**

**SESAME Light Source  
BM02-IR Beamline Principal Scientist/Responsible**

**Assoc Prof *on Leave*: Department of Physics,  
Faculty of Science, Capital Uni., Cairo, Egypt**



The theory..



# The experiment..

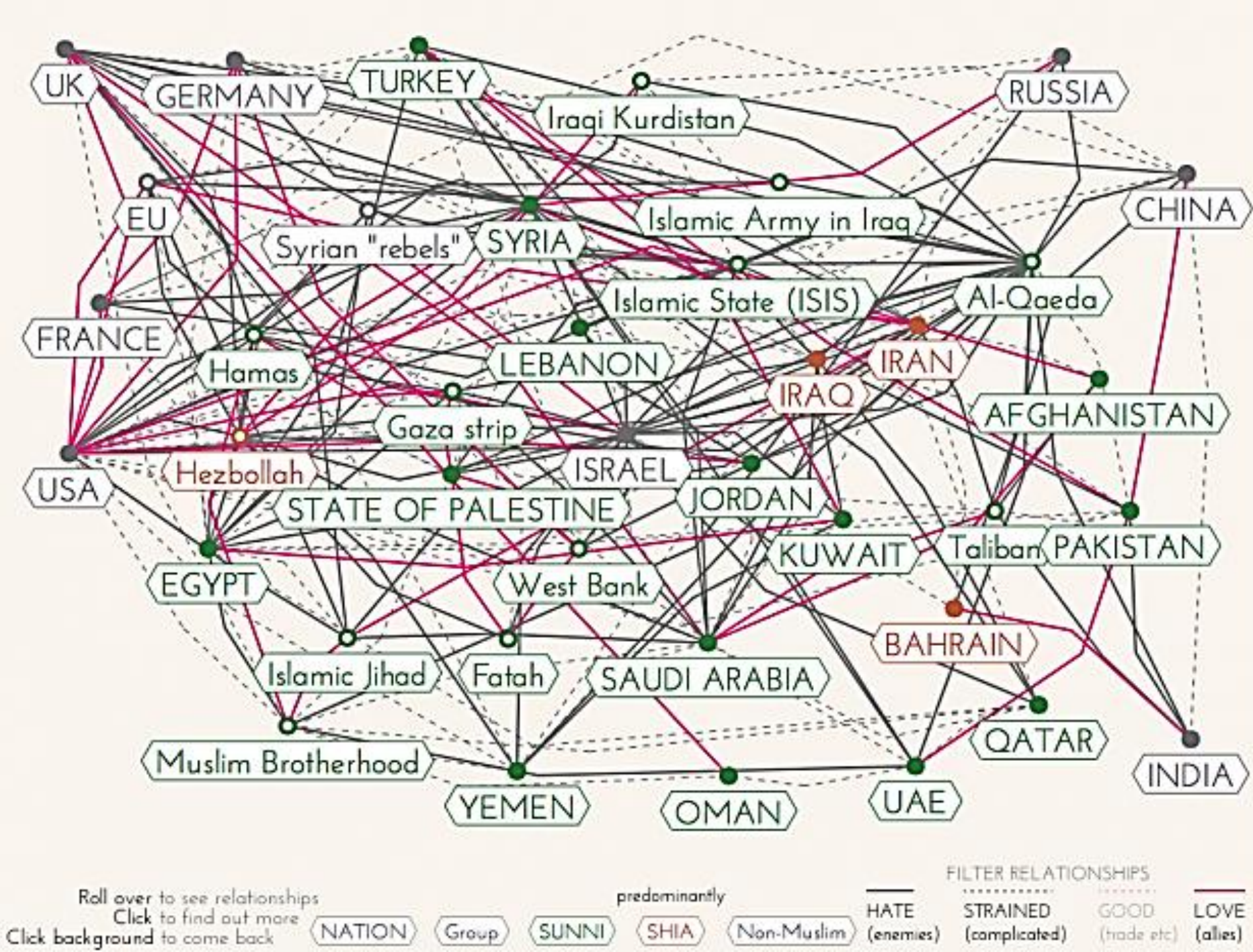

# The Middle East and another war..



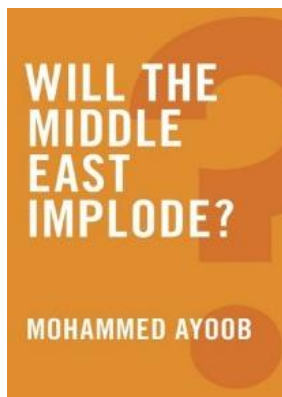
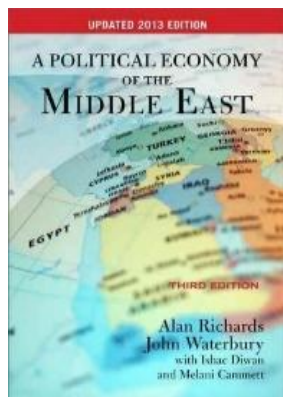
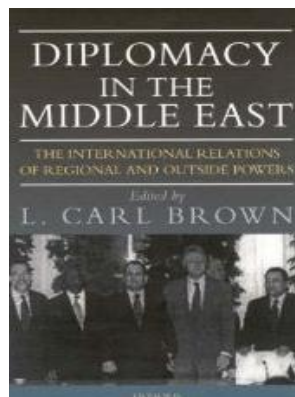
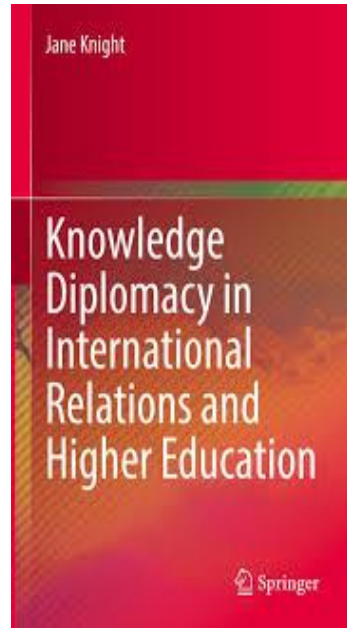
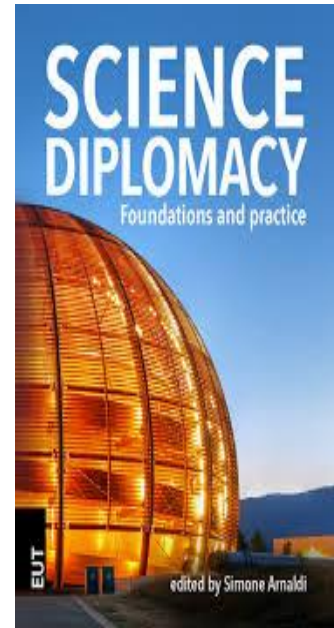
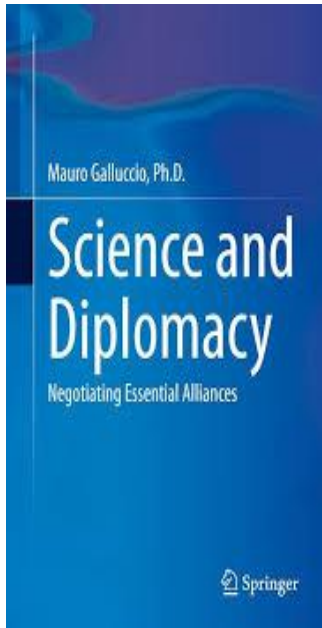
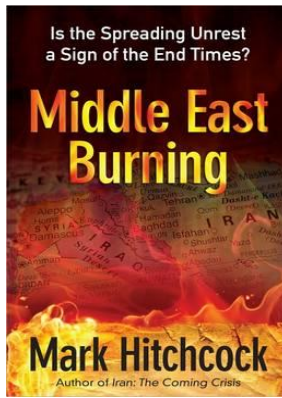
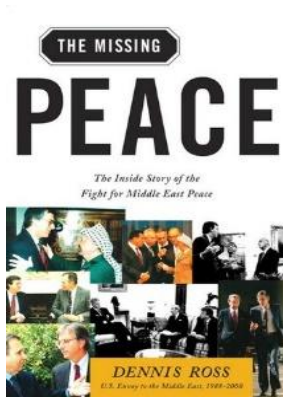
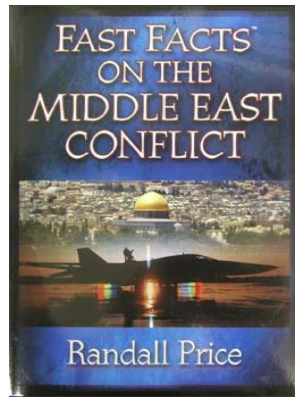
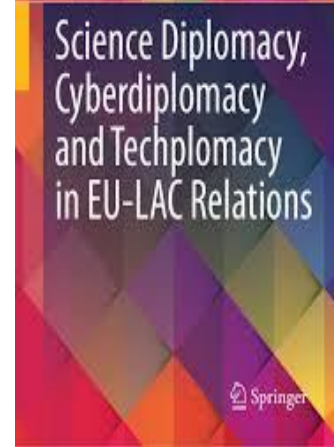
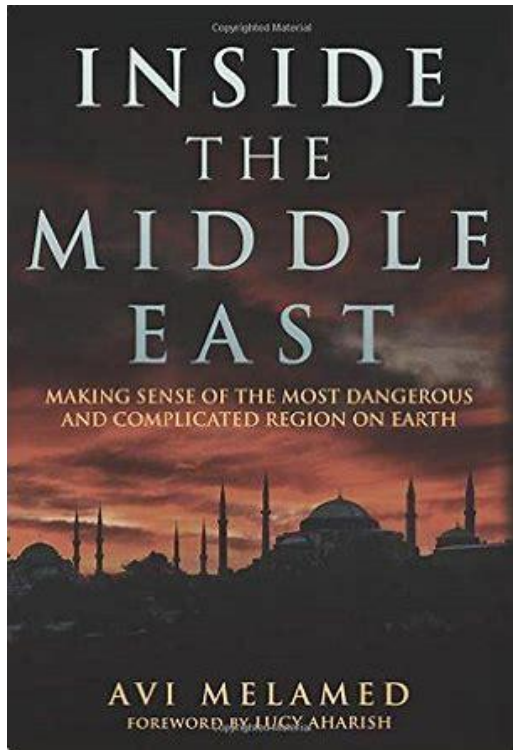
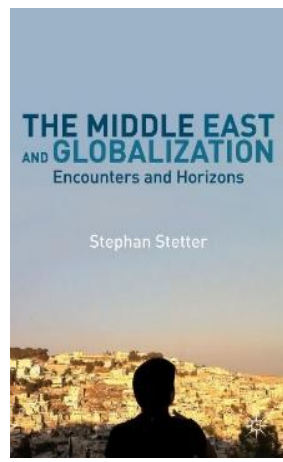
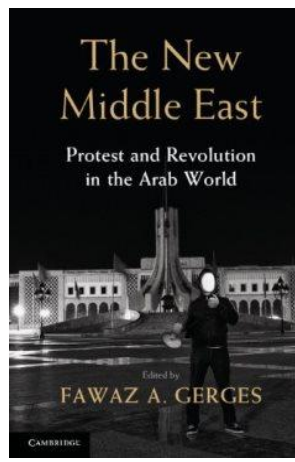
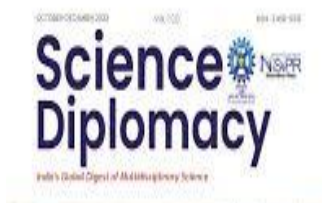



“Regionally-shared problems can best, or only, be solved through cross-border collaboration. The similarities of culture and experience, coupled with a common language and history of scientific achievement make collaboration an obvious strategy.\*”

**Not enough..**

\*“Science Diplomacy in Arab Countries: The Need for a Paradigm Shift.”, [Nart Dohjoka](#), [Cathleen A. Campbell](#), [Brenna Hill](#), AAAS Science and Diplomacy, 2017

# Lesson: Successful Bridge Building Through Scientific Collaboration



## Scientific Collaboration

Joint efforts in research and technology among nations

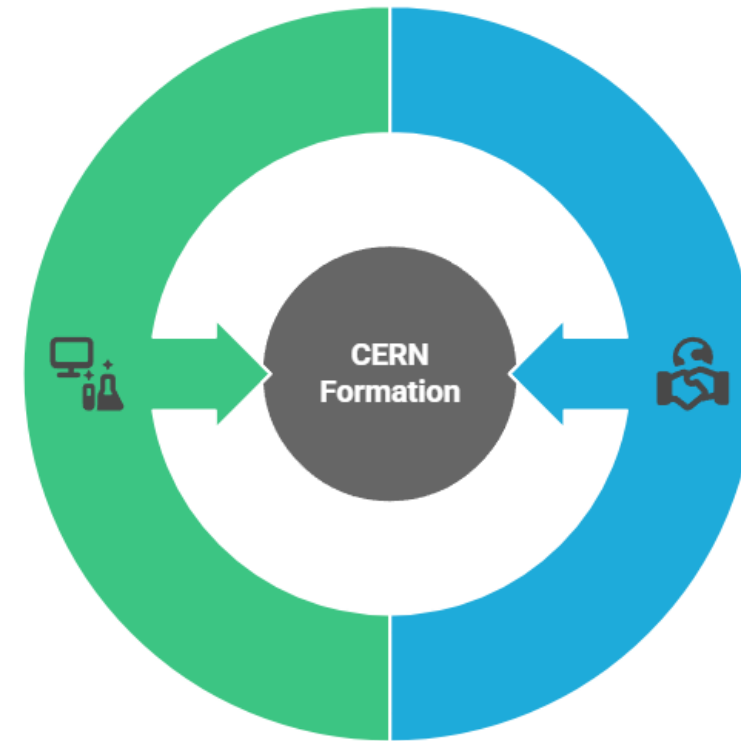

## Diplomatic Efforts

Efforts to negotiate and maintain peace between nations

**“Diplomatic Science does not work. Excellent science must be a major driving force, and is a necessary condition for building sound bridges..”**

**Science + Diplomacy?**

# Science Diplomacy in Action..

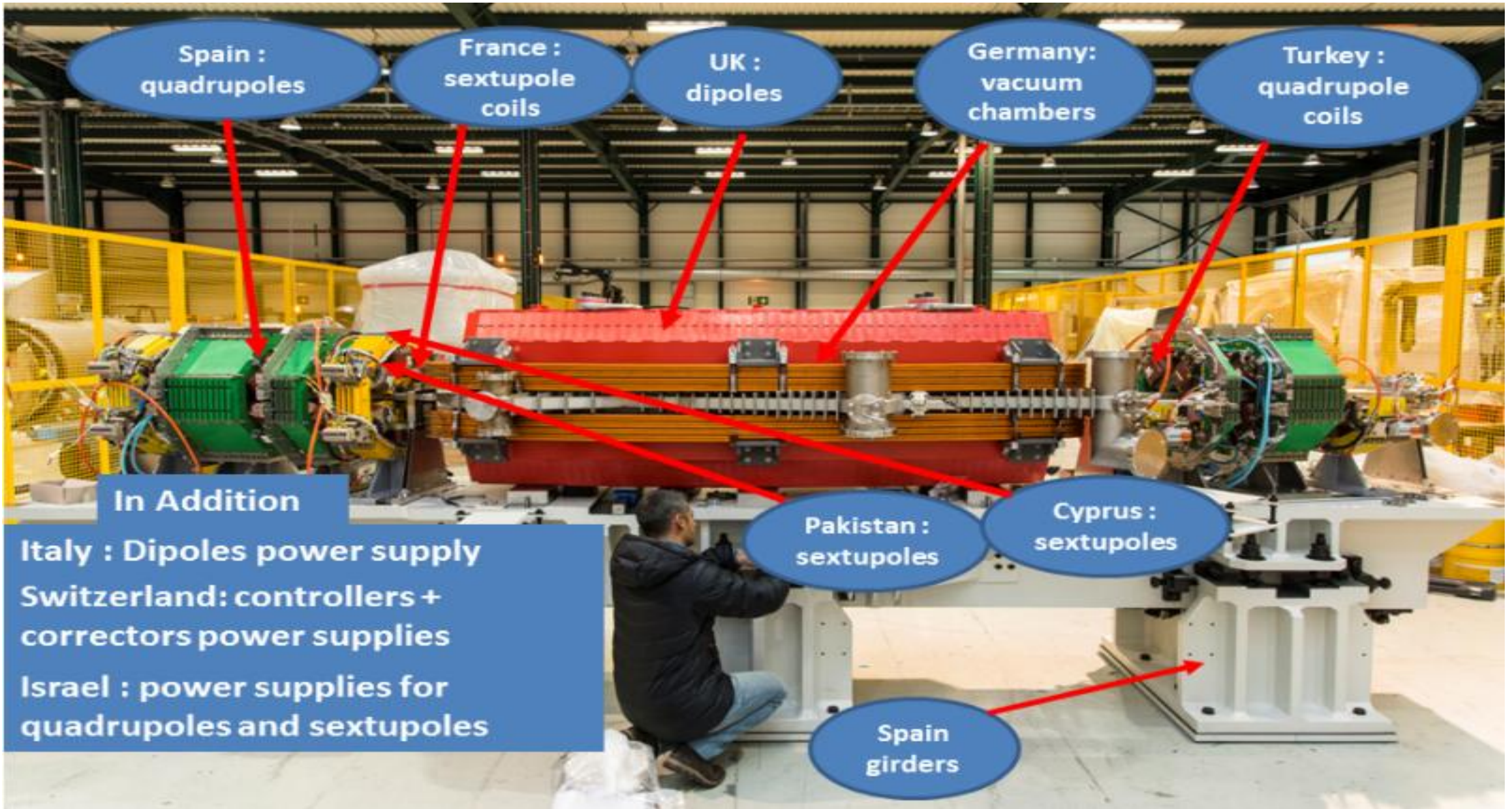

$$1 + 1 = 2$$





**Modelled on CERN**

**Intergovernmental Organization at the service of its Members and the whole world**



# SESAME Members



**Germany (Associate Member) - 2025**

**Model in action: RI for Science Diplomacy → Developing Pan Africanism**

**SESAME: Synchrotron light for Experimental Science and Applications in the Middle East**





# SESAME and the International Cooperation: from conception to operation

**BESSY I**



**SESAME 2002**



**+ Extensive upgrade  
+  
Brand-new machine**

**SESAME 2026**



Images are subjected to copyrights

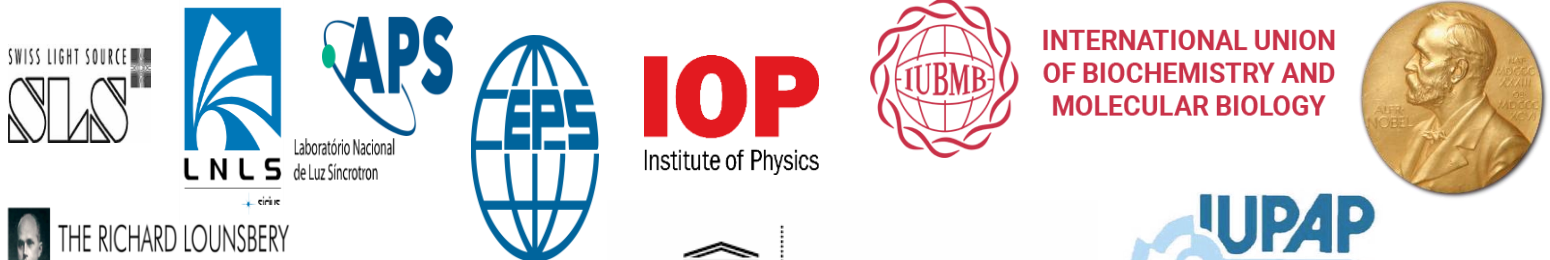

# SESAME Observers



Brazil, Canada, China, the European Organization for Nuclear Research (CERN), the European Union (EU), France, **Germany**, Greece, Italy, Japan, Kuwait, Portugal, the Russian Federation, Spain, Sweden, Switzerland, UAE, UK and the USA.



# External Support for SESAME

Advice from Members  
of Advisory Committees

Equipment or Cash for  
Equipment

Training (Users'  
meetings, Workshops,  
Individual training,  
Visits, Fellowships.)



## SESAME Opening Ceremony, May 16, 2017

HM King Abdullah II at the opening of SESAME with Heads of the delegations of the SESAME Members, Directors-General of Intergovernmental Organizations, President SESAME Council and SESAME's Directorate. Left of the King, HRH Princess Sumaya, head of Jordan's delegation; and Fabiola Gianotti, Director General CERN; to his right, Irina Bokova, Director-General UNESCO; Carlos Moedas, EC Commissioner for Research, Science and Innovation; and Rolf Heuer, President-Elect SESAME Council. Directly behind the King, Chris Llewellyn Smith, President SESAME Council with on left Khaled Toukan, Director SESAME. Back far left Yukiya Amano, Director General IAEA

# 2018: SESAME became the first Associate of LEAPS



On signing the Declaration of Association to the LEAPS Consortium with Helmut Dosch, Chair of LEAPS and Chair of the DESY Board of Directors, Rolf Heuer, President of the SESAME Council.





**2019: SESAME became the World's FIRST large accelerator complex fully powered by renewable energy – EU Support**

The necessary funding for the solar power plant became available in late 2016 when the Government of Jordan through the Ministry of Energy, generously agreed to allocate US\$7.05 million from funds provided by the European Union (EU) to support the deployment of clean energy sources.

**CLIMATE  
NEUTRAL**

**MEASURE  
REDUCE  
OFFSET** **NOW**

SESAME Synchrotron - 100%  
synchrotron light, 0% carbon  
dioxide

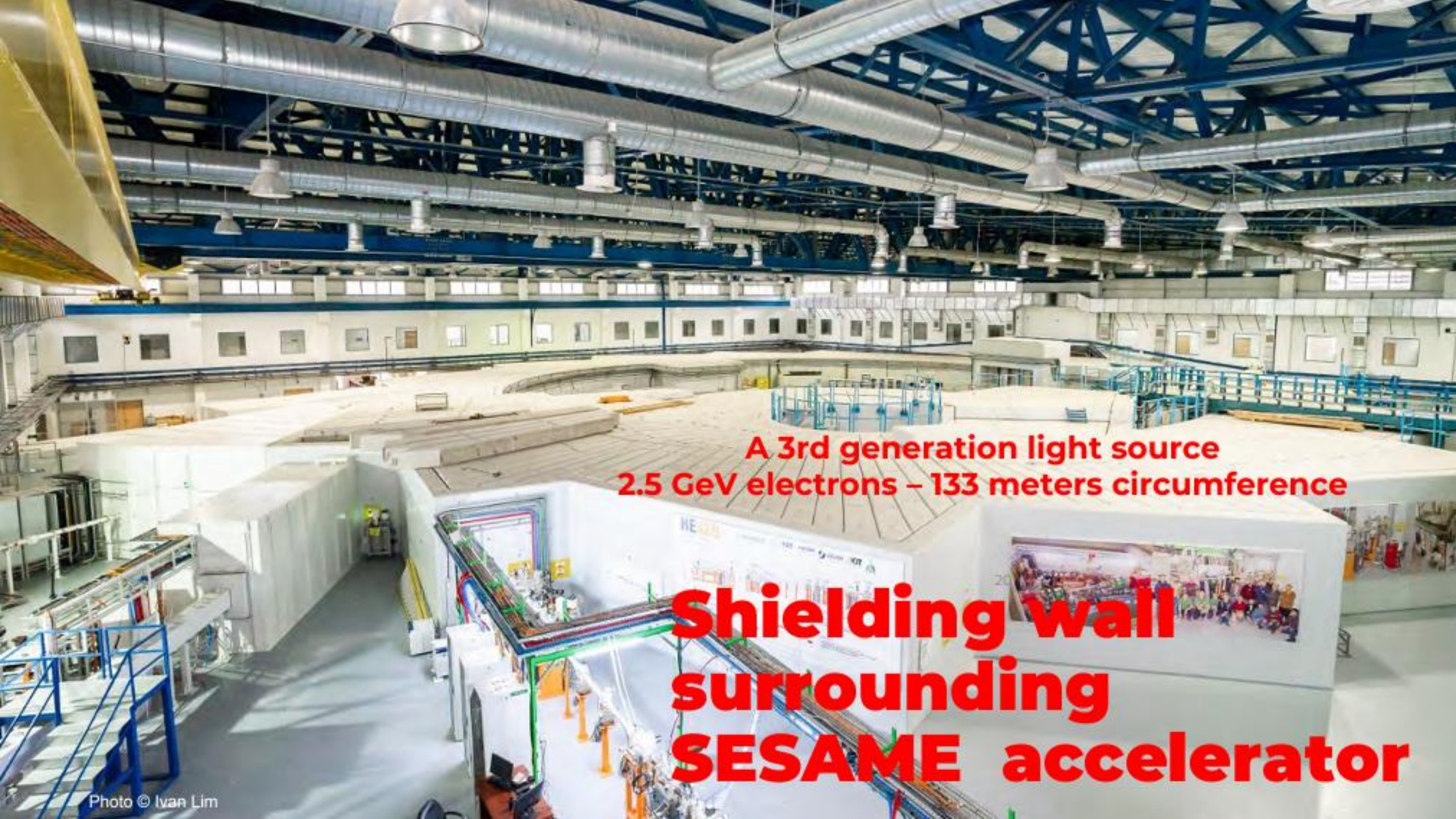

**A 3rd generation light source  
2.5 GeV electrons – 133 meters circumference**

**Shielding wall  
surrounding  
SESAME accelerator**



**BM08 XAFS/XRF**

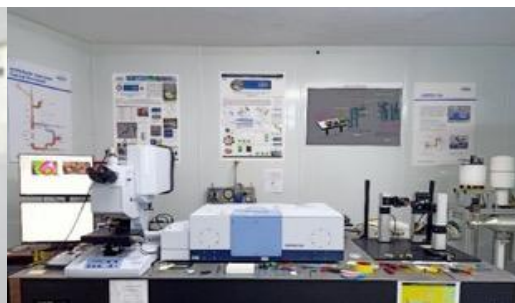

**BM02 IR**



**ID09 MS/XPD**

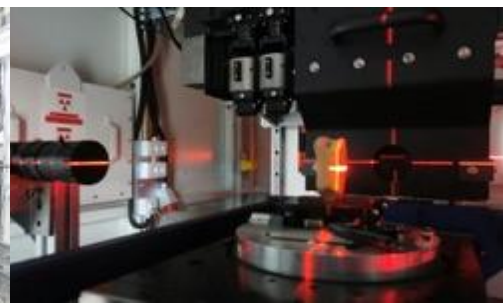

**ID10 BEATS**



**ID11L HESEB  
+ ID12 TXPES**

**.. An African Beamline?**



# Illuminating Science

Environment  
Food processing



Biology  
Medicine  
Pharmacy  
Cosmetics

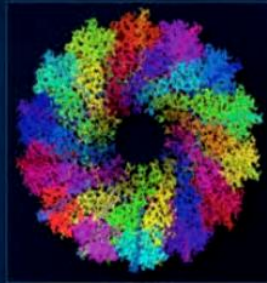

Materials  
Nanotechnology



Energy  
Chemistry

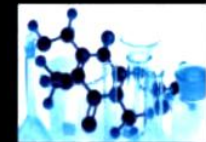

We see the  
invisible



Archaeology  
Cultural heritage



Spectre  
électromagnétique



Geophysics  
Astrophysics

This document was produced with the support  
of the education authority of Versailles



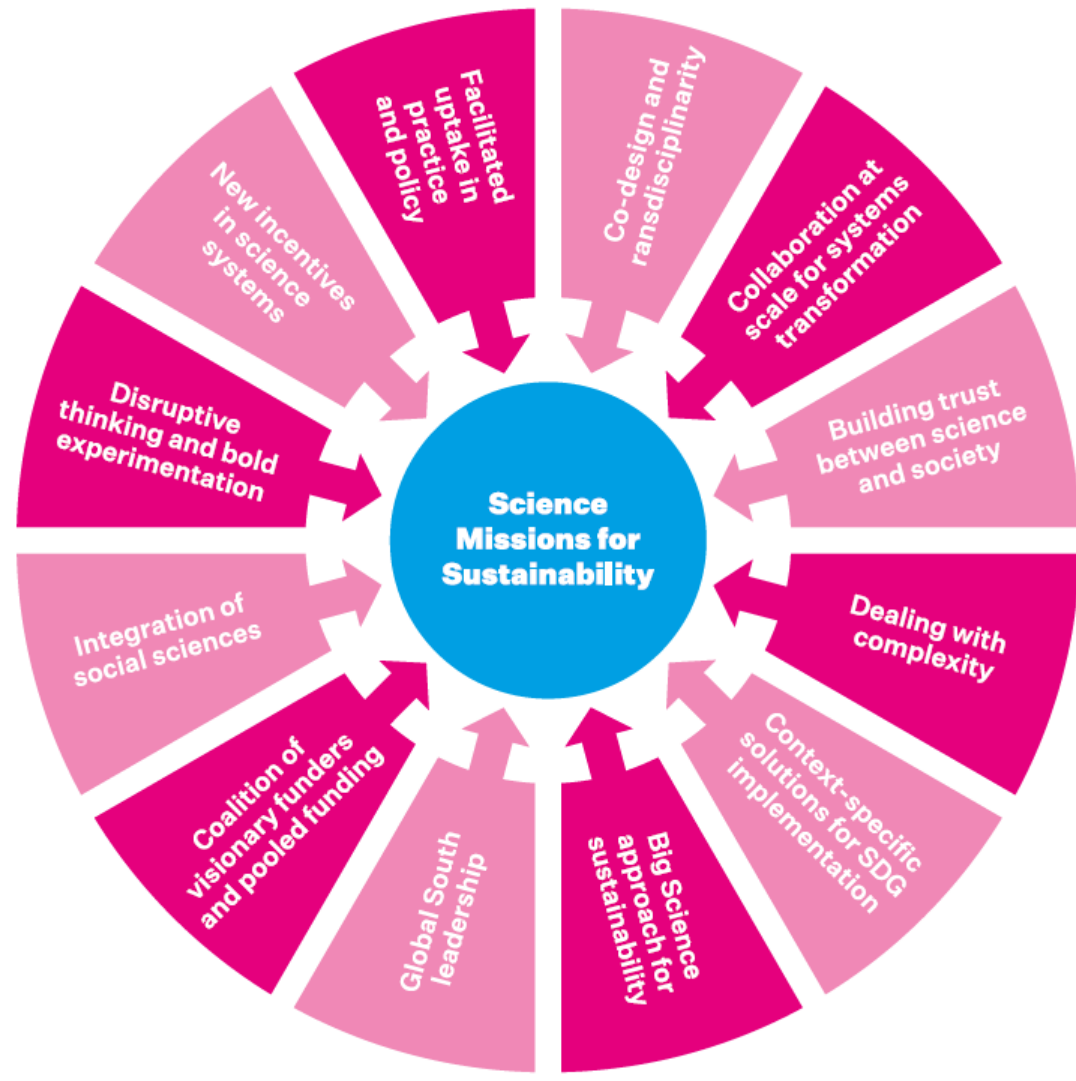

# Brain-Drain reversal

*“The map confirms that low- and middle-income countries are the most severely affected by inventor “brain drain”..”*

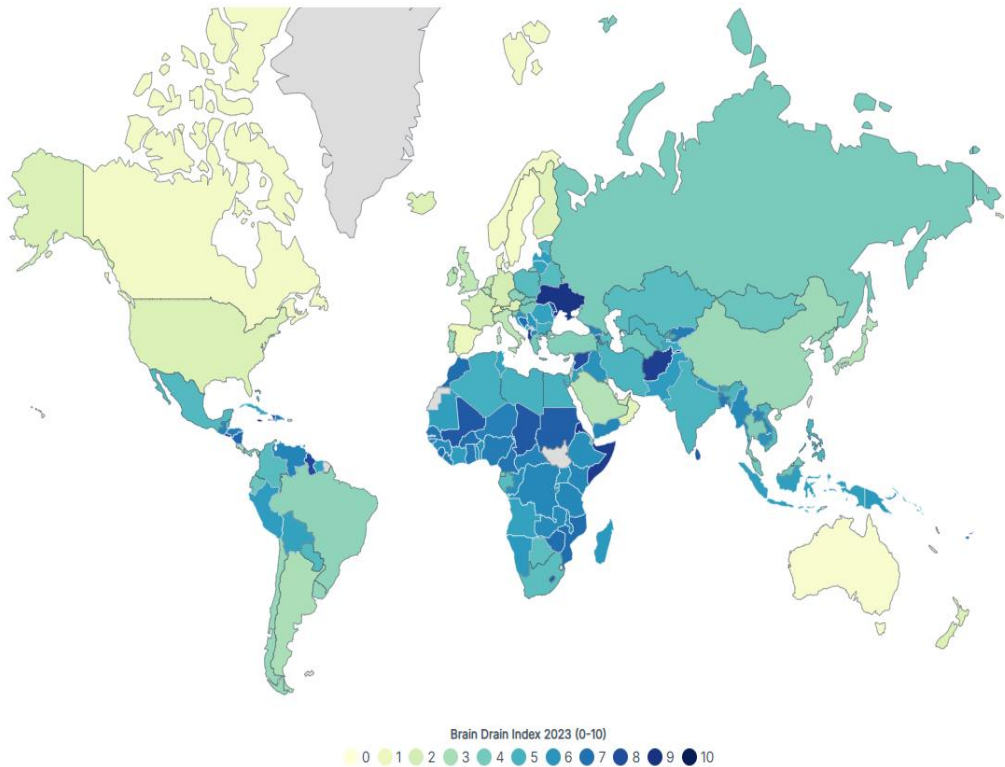

**Large scale emigration with technical skill and knowledge**

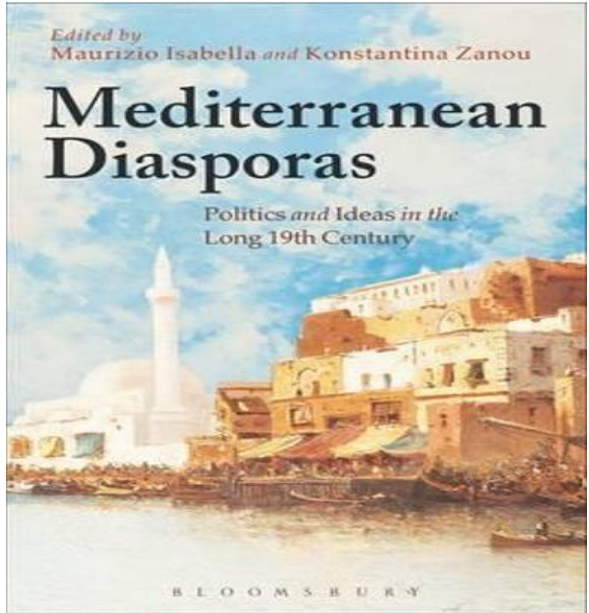
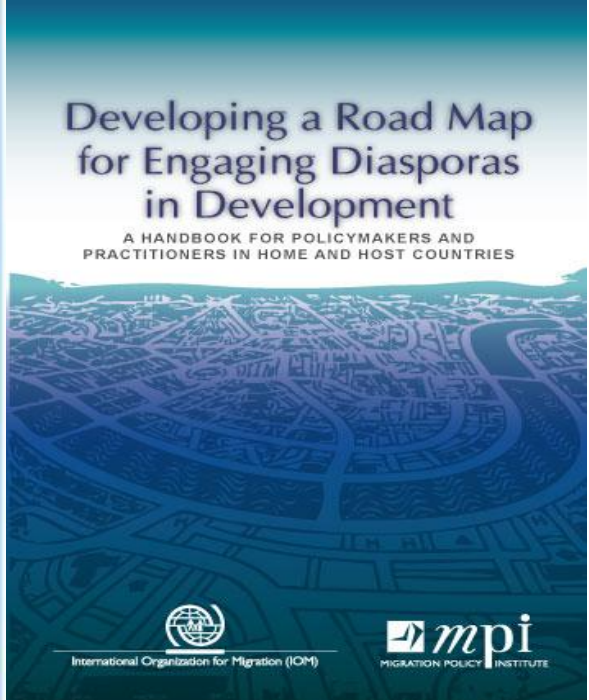
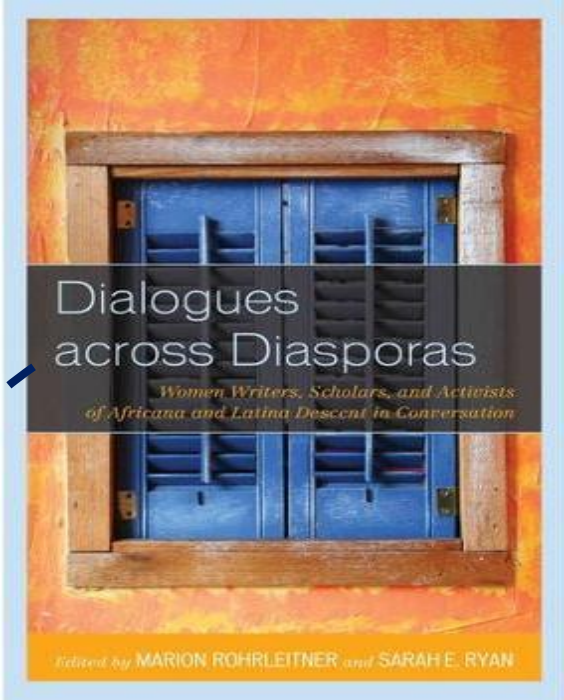



TRENDING

23/10/2024 16:42

# La fuga di cervelli è costata all'Italia circa 134 miliardi negli ultimi 13 anni



# Equal Opportunity

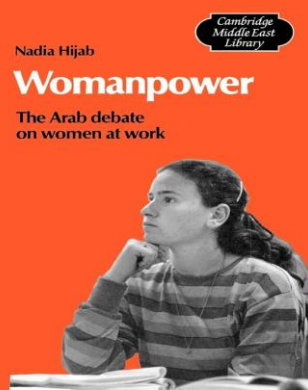
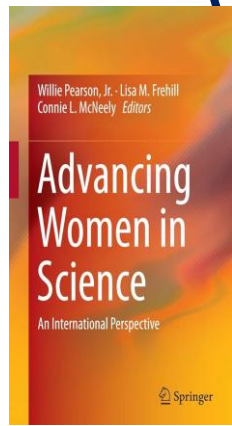
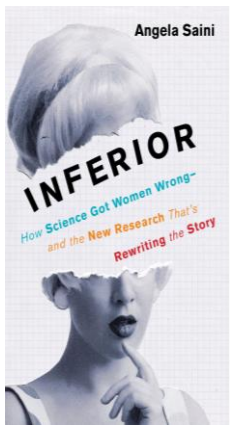
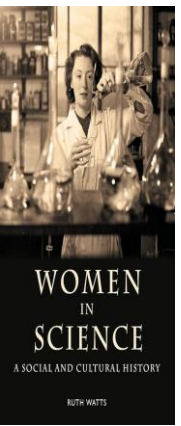
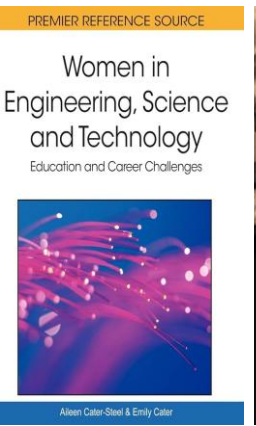
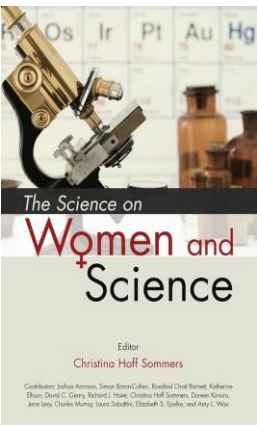
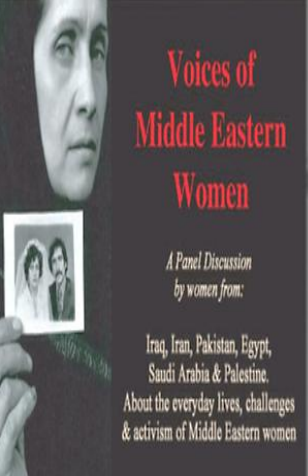
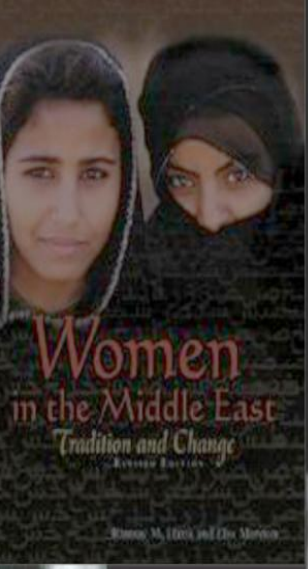
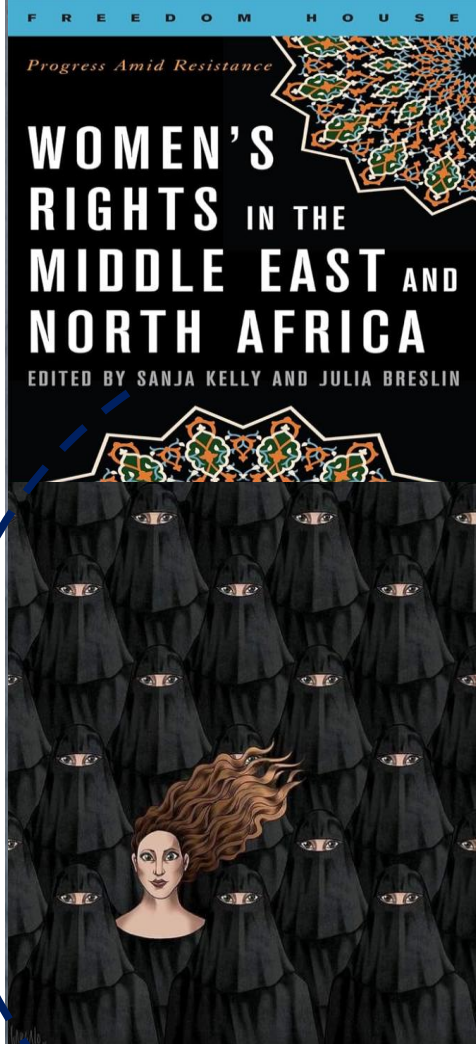
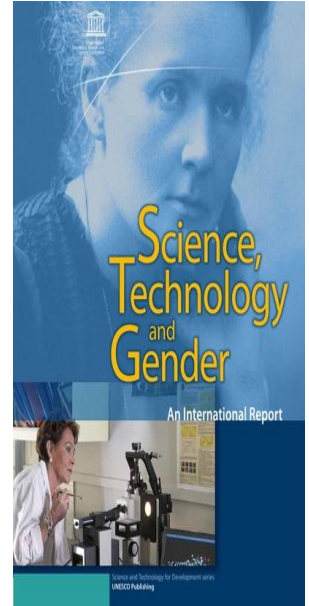
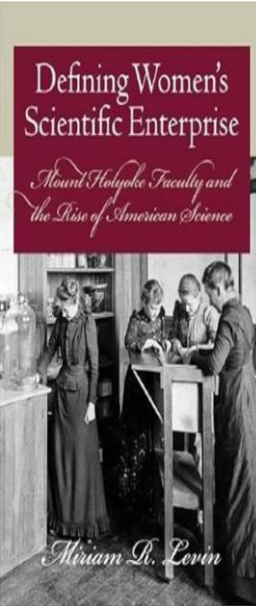
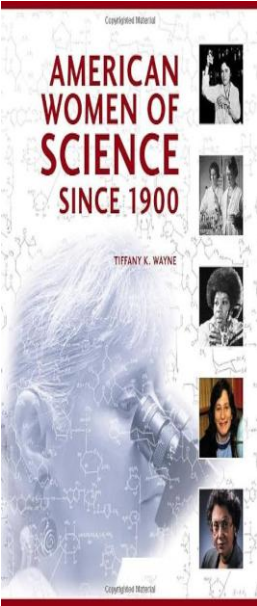

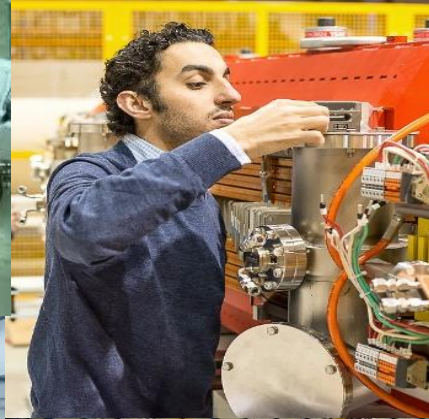

**If you want to walk fast, walk alone, If you want to walk far, walk together.**

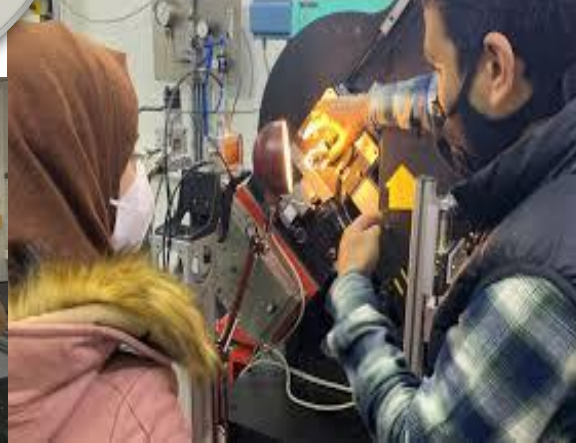

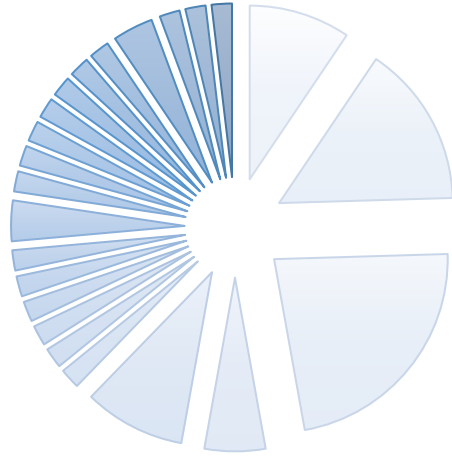

- Cyprus
- Türkiye
- Malta
- France
- Malaysia
- UK
- South Africa**
- Israel
- Algeria**
- Nigeria**
- Senegal**
- Jordan
- Iran
- Germany
- Palestine
- Pakistan
- Qatar
- Mexico
- Benin**
- Morocco**
- Botswana**
- Egypt \* SESAME Member**
- Italy
- Belgium
- Japan
- UAE
- Iraq
- Colombia
- Cameeron**
- Kenya**
- Zimbabwe**



.. Transferring the know-how through collaborations, training opportunities, and networking proves to establish a tangible implementation of the SDGs..





**Budget: 10 MEUR**  
**Run time: 1 May 2017 – 31 October 2021**

**Convenient Access to Light Sources Open to Innovation, Science and to the World.**

The aim of the CALIPSOplus project was to remove barriers for access to world-class accelerator-based light sources in Europe and in the Middle East. To this end, more than 179,000 hours of trans-national access have been provided to these research infrastructures and specific programmes were installed to teach new users how to successfully use synchrotrons and FELs.

Dissemination activities targeting industry were complemented by tailor-made support and access programmes for this user group. In parallel the consortium was collaborating on constantly developing technology to keep the facilities at the cutting-edge.

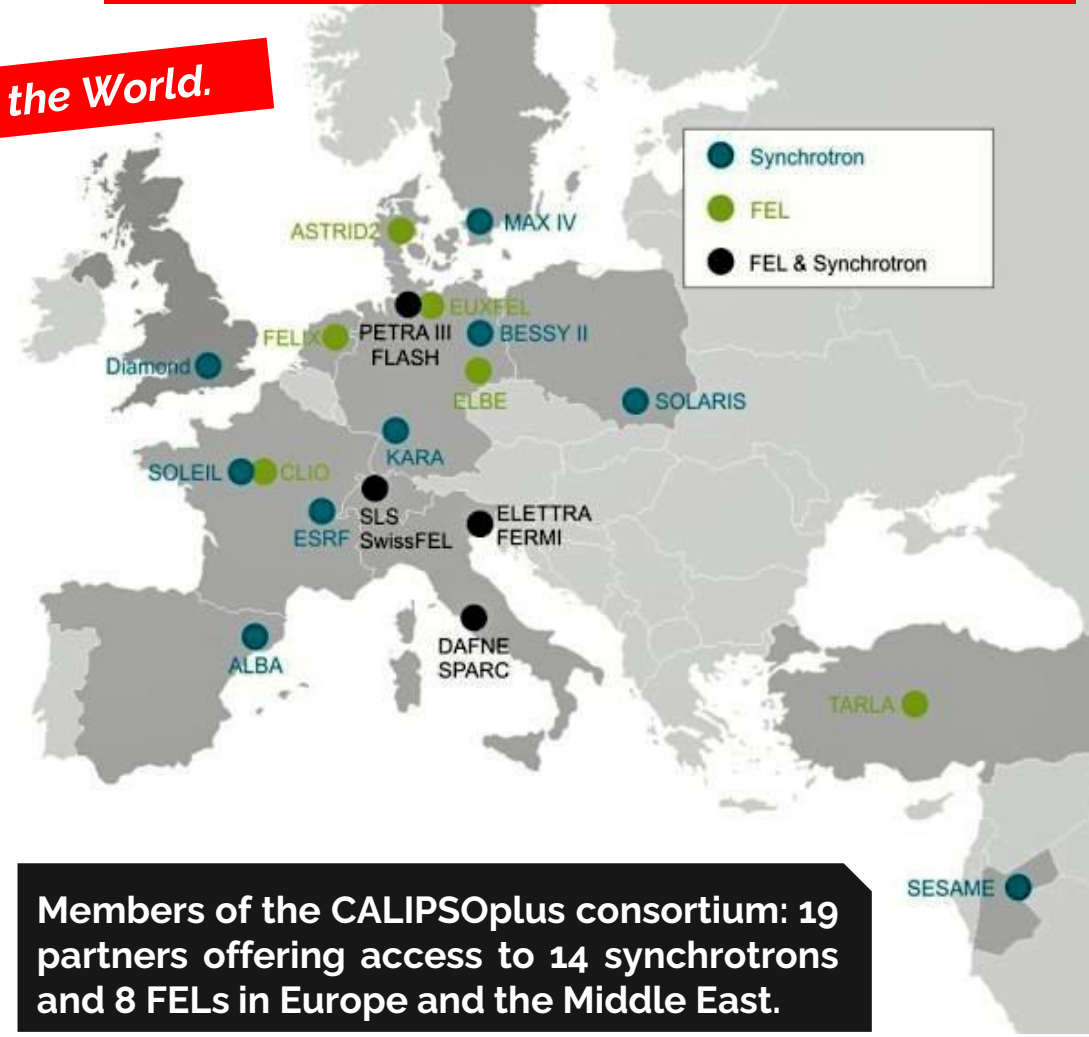

**Members of the CALIPSOplus consortium: 19 partners offering access to 14 synchrotrons and 8 FELs in Europe and the Middle East.**



**CALIPSOplus is an Integrating Activity for Advanced Communities in reply to the call INFRAIA-01-2016 (Material Sciences and Analytical facilities/ Synchrotron radiation sources and Free Electron Lasers) in Horizon2020 the European Framework Program for Research and Innovation. This project has received funding from the European Union's Horizon 2020 Research and Innovation programme under Grant Agreement No 730872.**

<https://www.calipsoplus.eu/>



# Opening Synchrotron Light for Experimental Science and Applications in the Middle East

The OPEN SESAME project aimed at ensuring optimal exploitation of the Synchrotron light for Experimental Science and Applications in the Middle East (SESAME) light source.

The project addressed the INFRASUPP-2016-2017 call to support SESAME. OPEN SESAME was well aligned to the broader scope of the work programme with activities having a lasting impact on a reinforced European Research Area, and particularly in strengthening international cooperation for research infrastructures with a key Region located close to Europe.

**EC signature date**

21 November 2016

**Start date**

1 January 2017

**End date**

31 December 2019

**Funded under**

EXCELLENT SCIENCE - Research Infrastructures

**Total cost**

€ 2 100 823,75

**EU contribution**

€ 1 957 323,75

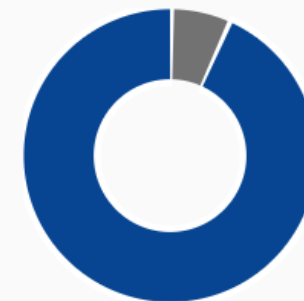

**Coordinated by**

EUROPEAN SYNCHROTRON RADIATION FACILITY

France



OPEN-SESAME project has received funding from the EU's H2020 framework programme for research and innovation under grant agreement n.730943

<https://cordis.europa.eu/project/id/730943>



Elettra Sincrotrone Trieste

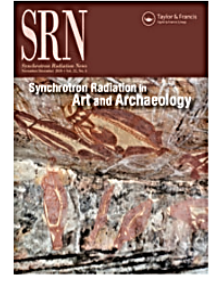
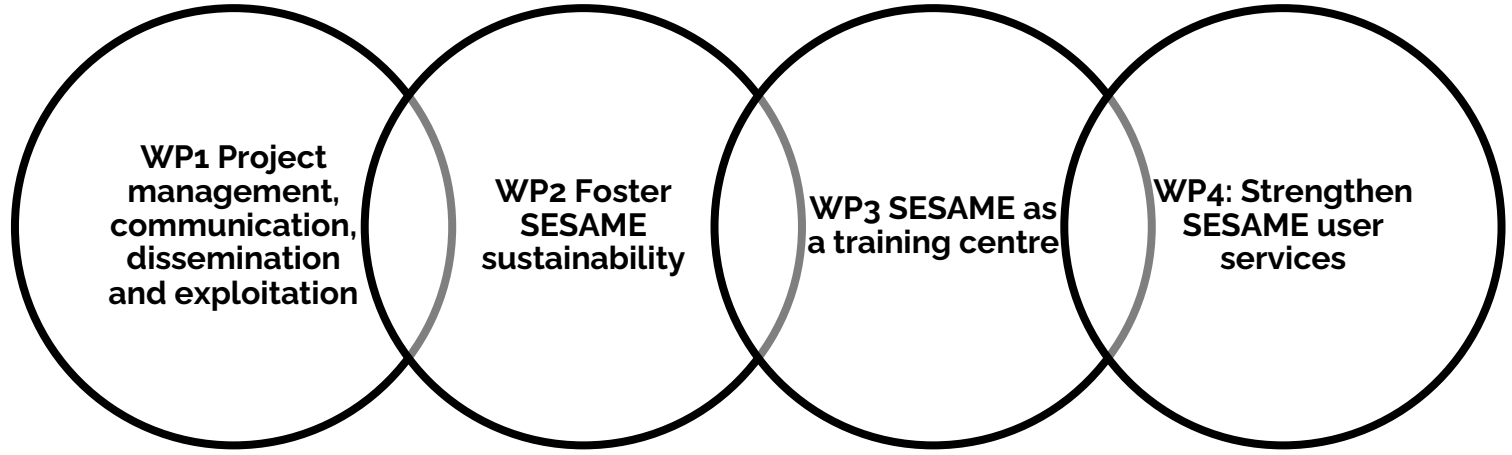

Synchrotron Radiation News



ISSN: 0894-0886 (Print) 1931-7344 (Online) Journal homepage: [www.tandfonline.com/journals/gsrn20](http://www.tandfonline.com/journals/gsrn20)



Istituto Nazionale di Fisica Nucleare



SESAME



## OPEN SESAME: A Horizon2020 Project to Help the SESAME Light Source

M. A. G. Aranda, G. Facile, J. Gillies, N. Guimard, F. Lehner & E. P. Mitchell (on behalf of the OPEN SESAME consortium)

To cite this article: M. A. G. Aranda, G. Facile, J. Gillies, N. Guimard, F. Lehner & E. P. Mitchell (on behalf of the OPEN SESAME consortium) (2019) OPEN SESAME: A Horizon2020 Project to Help the SESAME Light Source, Synchrotron Radiation News, 32:6, 55-56, DOI: [10.1080/08940886.2019.1680222](https://doi.org/10.1080/08940886.2019.1680222)

To link to this article: <https://doi.org/10.1080/08940886.2019.1680222>

<https://cordis.europa.eu/project/id/730943>

## Inauguration of SESAME's Guest House

06 December 2019

The Guest House was constructed thanks to generous funds provided by the Government of Italy represented by the Ministry for Education, University and Research through INFN (Istituto Nazionale di Fisica Nucleare - National Institute for Nuclear Physics).

A commemorative plaque was unveiled by the Ambassador of Italy to Jordan, H.E. Mr Fabio Cassese, in the presence of the SESAME Director, H.E. Professor Khaled Toukan, the President of the SESAME Council, Professor Rolf Heuer, the President of INFN, Professor Antonio Zoccoli, as well as the former President of INFN, Professor Fernando Ferroni.





# Italy's Ambassador to Jordan inaugurates the new laboratory for Cultural Heritage at SESAME and welcomes SESAME'S inclusion in the INFN-CHNET network



© SESAME 2022: Cutting the ribbon at the IR Beamline (left to right): the Director of SESAME, Professor Khaled Toukan and the Ambassador of Italy to Jordan, H.E. Mr. Fabio Cassese Note: all picture participants are Covid-19 Vaccinated.

## SESAME's injector brought to a higher level of performance with installation of 2 Solid State Modulators for its Microtron

02 April, 2023

“...SESAME's two new Solid-State Modulators (SSMs) for its Microtron came into operation. They replace the Microtron PFN- (Pulse Forming Networks) based modulator previously used in the Microtron system.

These SSMs were constructed by ScandiNova in Uppsala (Sweden) and were generously funded by Italy's National Institute for Nuclear Physics (**INFN**) and Switzerland's Paul Scherrer Institute (PSI).”





**BEATS, the BEAmline for Tomography at SESAME is an H2020 European project to build a beamline for tomography at the SESAME synchrotron in Jordan.**



© SESAME 2023: Dignitaries formally inaugurate BEATS. Cutting the ribbon are (left to right): Prof. Azmi Mahafzah, Minister of Higher Education and Scientific Research of Jordan, SESAME Director, Khaled Toukan and H.E. Ms Maria Hadjitheodosiou, Ambassador of the European Union to Jordan.

# SESAME's cooling system gets a major upgrade: Another step towards increased efficiency

25 March, 2025

“...This major upgrade to the cooling system was carried out by the Technical Sector in August 2024, and the new system is now fully integrated with the EPICS system, giving the machine operators a seamless control interface, and making it much easier to control the temperature in the accelerator and experiment areas. It was made possible thanks to the generous financial support from the Istituto Nazionale di Fisica Nucleare (**INFN**).”

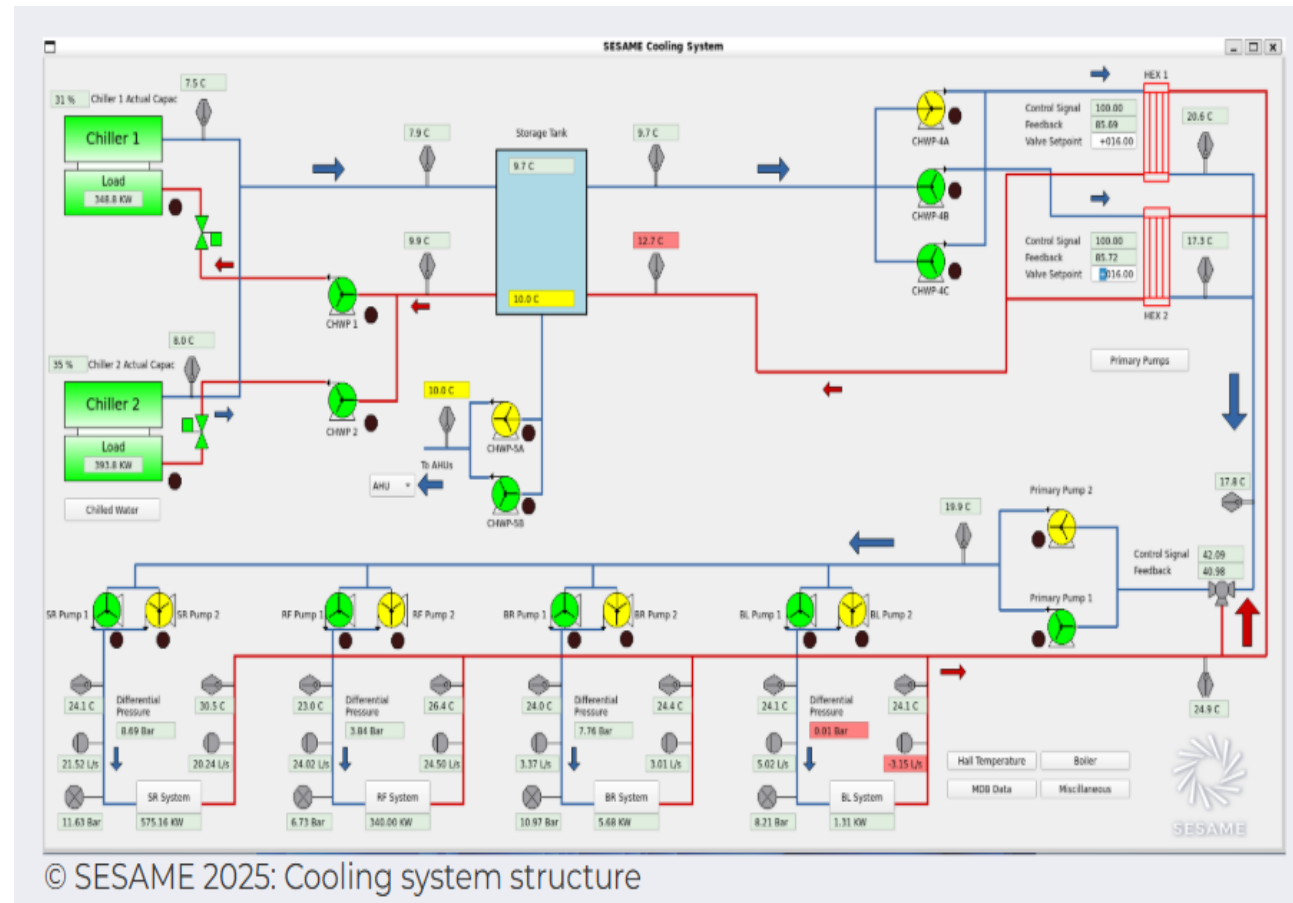



# SUNSTONE

Enhance the research capabilities of researchers from the Middle East and Africa

Promote the use of synchrotron radiation techniques in the region

Foster collaboration and knowledge sharing among researchers

Support the development of scientific infrastructure in the region

Contribute to the achievement of the SUNSTONE project's objectives of strengthening the scientific capacity and service provision of the SESAME light source and its position as an international research infrastructure

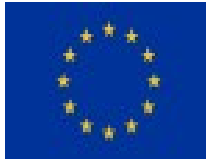

Funded by the European Union. Views and opinions expressed are however those of the authors only and do not necessarily reflect those of the European Union or the European Research Executive Agency (REA). Neither the European Union nor the granting authority can be held responsible for them. Grant agreement n. 101177314.



Elettra Sincrotrone Trieste

**ESRF – Coordinator**



**Addressing Global Societal Issues**

Leverage SESAME's capabilities to tackle significant global challenges.



**Amplifying International Influence**

Increase the global influence of European light sources and their collaboration with SESAME.



**Broadening and Educating User Community**

Widen the user community on light source techniques and strengthening the user support of SESAME.



**Developing African Research Capacity**

Support the access of African researchers to synchrotron radiation activities.

## Strategic Approach



**Elevating User Support Quality**

Improve the quality of user support at SESAME facilities.



**Enhancing Visibility and Membership**

Promote SESAME through targeted outreach and promotional activities.



**Ensuring Long-term Sustainability**

Secure SESAME's role in fostering scientific advancement in the region and beyond.

**“Science alone cannot solve the many political, security, and economic problems that we are facing today. However, science diplomacy still has an important role to play in addressing health, environment, energy, water, and food challenges that contribute to regional instability.”**

**Thank you**

